

Cast IR Receiver Packaging Options

Vishay Semiconductors



IR Receiver Modules for Remote Control Systems

Vishay offers stock Cast IR Receivers in three different packages:
 loose packed in tubes and mounted on tape for reel or ammpack.

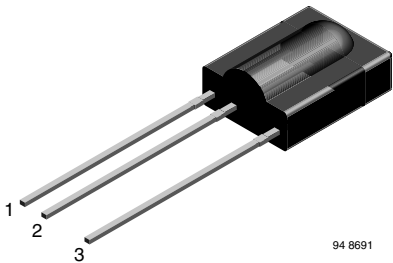

FEATURES

- Compliant with RoHS 2002/95/EC and WEEE 2002/96/EC



AVAILABLE FOR:

- TSOP312..
- TSOP311..
- TSOP12...
- TSOP11...
- TSOP13...



LOOSE PACKED IN TUBE

ORDERING INFORMATION

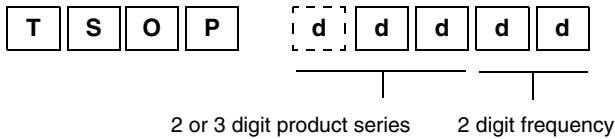

Note

d = "digit", please consult the list of available devices create a valid part number.

Example: TSOP1238

PACKING QUANTITY

- 54 pieces per tube
- 20 tubes per carton

PACKAGING DIMENSIONS in millimeters

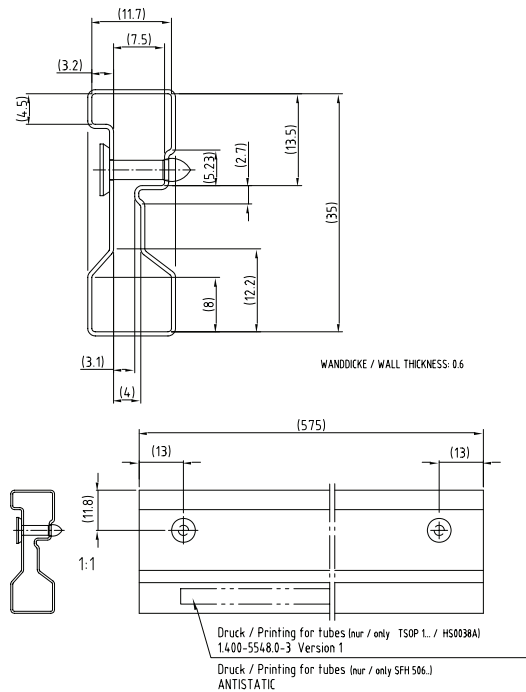

Drawing-No.: 9.700-5131.0-4
 Rev. 10; Date: 20.11.03
 20000-1



Cast IR Receiver Packaging Options

IR Receiver Modules for
Remote Control Systems

Vishay Semiconductors

TAPE AND REEL/AMMOPACK

Up to 3 consecutive components may be missing if the gap is followed by at least 6 components. A maximum of 0.5 % of the components per reel quantity may be missing. At least 5 empty positions are present at the start and the end of the tape to enable insertion.

Tensile strength of the tape: > 15 N

Pulling force in the plane of the tape, at right angles to the reel: > 5 N

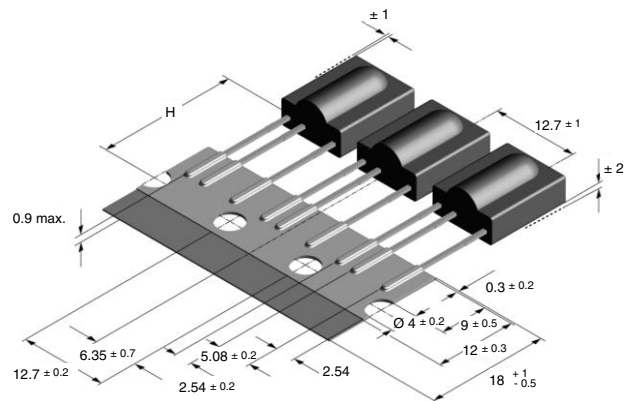
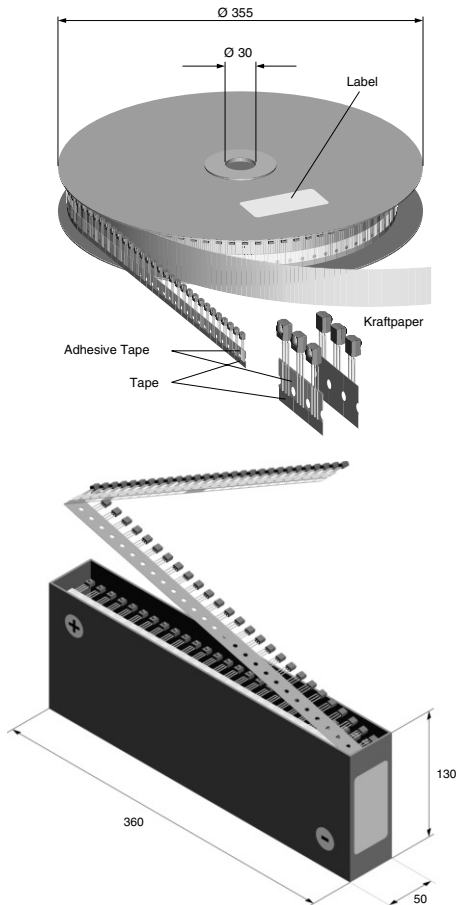

ORDERING INFORMATION

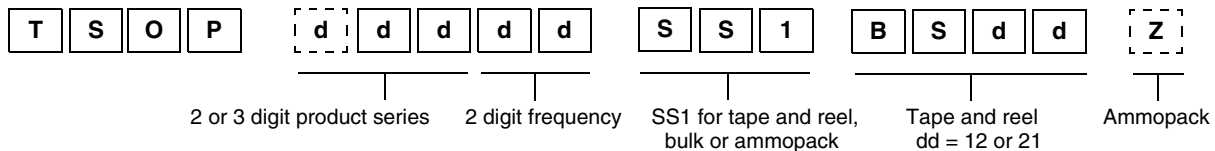

Note

d = "digit", please consult the list of available devices create a valid part number.

Example: **TSOP1238SS1BS12**
TSOP1238SS1BS12Z

PACKING QUANTITY

- 1000 pieces per reel
- 1000 pieces per ammopack